

## R&D Fund Project

### Assesment of Fault Level Management For TNB Distribution System

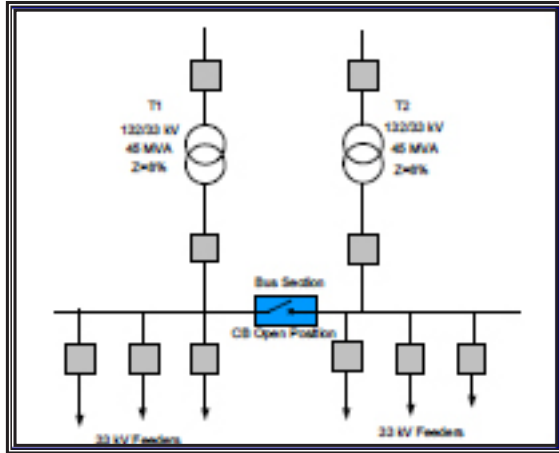

Reducing Fault Level by Network Splitting



Superconducting Fault Current Limiter (Germany)

### Project Overview

Fault level in the TNB distribution network, particularly in the Klang Valley, is on the rise due to increase in generation and interconnection following rapid growth in demand of electricity in the country as well as the need to improve reliability of supply. Proper measures must be taken in planning and operating the system such that the fault level should not exceed the equipment's rating or otherwise the security and reliability would be compromised. This project has been undertaken to investigate the issues in managing the fault level current within the TNB Distribution network.

### Deliverables

- Assessment of the fault current level issues at selected TNBD network
- Recommendations on the key approaches in managing the fault level problems and suitable mitigating techniques available
- Assessment of the existing fault current level limits and feasibility of reviewing the shorttime rating of equipments in TNBD

### Benefits

- The project provides better understanding on the fault level management and its limit at selected critical areas.
- Assessment is given on potential techniques and technologies that can be utilized.
- This will assist in future network planning and ways to address existing fault level constraints